

ENERGYMID|EM

Modbus RTU Interface for Energy Meters U228X-W7 and U238X-W7

3-349-910-03
3/4.19

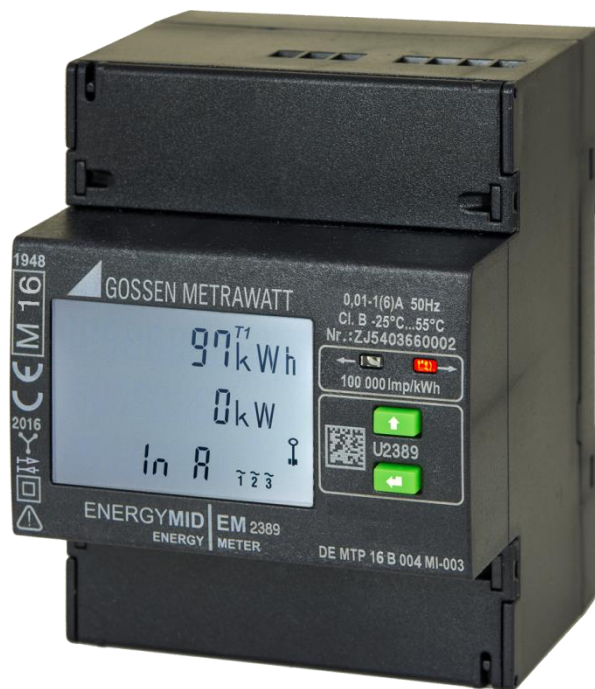

Table of Contents

1	Hardware	4
1.1	Modbus / RS 485 Standard	4
1.2	Electrical Connection	4
1.3	Bus Topology.....	4
1.4	System Requirements	4
2	Software	5
2.1	Coding	5
2.2	Bus Timing.....	5
2.3	Frame Layout.....	6
2.4	Addressing.....	6
2.5	Function Codes.....	6
2.6	Data	6
2.7	CRC Calculation (cyclic redundancy check)	6
2.8	Error Handling.....	7
2.9	Function Code Examples	9
3	Address Space	11
3.1	Address Overview	11
3.2	Variable Types.....	12
3.3	Format Types.....	12
3.3.1	Format Type 1 (voltage, current, power)	12
3.3.2	Format Type 2 (energy).....	12
3.3.3	Format Type 3 (frequency)	13
3.3.4	Format Type 4 (power factor)	13
3.3.5	Format Type 5 (THD)	13
3.3.6	Format Type 6 (error status flags 1).....	14
3.3.7	Format Type 7 (error status flags 2).....	14
3.3.8	Format Type 8 (RTC structure)	15
3.3.9	Format Type 9 (interface hardware and firmware versions)	15
3.3.10	Format Type 10 (operating logbook entry)	16
3.3.11	Format Type 11 (counter reading profile entry).....	17
3.3.12	Format Type 11a (counter reading profile status 1)	18
3.3.13	Format Type 11a (counter reading profile status 2)	19
3.3.14	Format Type 12 (device information).....	20
4	Variables in the Address Space	22
4.1	Address Space with Flexible Addressing (Modbus standard).....	22
4.2	Address Space with Fixed Block Size	30
5	Control and Display Functions	31
6	Application Notes	32
6.1	Notes regarding Initial Start-Up	32
6.2	Tariff Change via Interface	32
6.3	Operating Logbook and Counter reading profile	32
6.4	Cutoff Date Meter	33
6.5	Resettable Meter	33

7 **Product Support** 34

1 Hardware

1.1 Modbus / RS 485 Standard

The Modbus standard makes use of the EIA RS 485 standard. It defines the physical layer (PHY) of the Modbus interface. The data are transmitted in serial format via a 2-wirebus (RS 485). The information is coded as a differential signal in NRZ code (non return to zero).

1.2. Electrical Connection

A shielded, 2-wire twisted-pair cable should be used for electrical bus connection. Shielding and twisting eliminate or at least reduce the effects of interference and the bus's EMC characteristics are improved.

Terminal designations vary from manufacturer to manufacturer. A and B are commonly used to designate the bus connection. With this meter, A is the positive (+) and B the negative (-) bus connection. Depending on the manufacturer, these meanings of A and B are sometimes reversed. The bus connection can also be identified with + and - symbols. The terminal to which the shield is connected is frequently designated C. Depending on the manufacturer, other designations are possible in this case as well.

Shielding of the bus cable also provides for equipotential bonding of the bus. If it's not possible to use a shielded cable, at least a third conductor should be used for equipotential bonding. The shield or third conductor should be connected to the protective conductor (PE) at one point only. This connection is usually made at the master.

Note: Potential difference over the bus may not exceed $\pm 7 \text{ V}$.

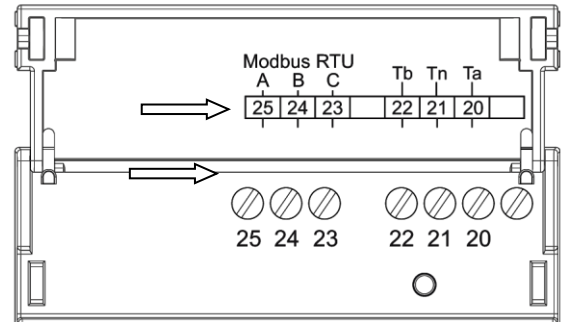

1.3 Bus Topology

The RS 485 standard defines the bus cable as a cable with a beginning and an end, each of which are terminated with a terminating resistor (R_T). Resistance of terminating resistor R_T should correspond to line impedance. Common values are 100 to 150 Ω .

Slaves are connected to the bus via a short cable, or they're connected directly to the bus which continues from there to the next slave. Star wiring is not possible.

The maximum number of slaves which can be connected to a bus depends on the so-called unit load of the interconnected slaves. Unit load = 1 is the worst case: a maximum of only 32 slaves can be connected to a master on the same bus in this case. The meters included in the U228x, U238x series have a unit load of 1/8. If meters from this series are used exclusively, up to 256 meters can be connected to the same bus.

Comment: In order to assure a defined open-circuit potential in the bus line when none of the Modbus users are transmitting, a pull-up resistor R_{PU} connected to internal supply voltage for the bus components and a pull-down resistor R_{PD} connected to reference potential are usually required for Modbus. When using series U228x and U238x Modbus meters, neither of these resistors is required because so-called failsafe receiver inputs are used.

1.4 System Requirements

Cable:	2-wire twisted-pair, shielded if possible, wave impedance: approx. 100 to 150 Ω , min. 0.22 sq. mm with terminating resistor on both ends (see section 1.3)
Cable length:	Max. 1000 m depending on cable type and transmission speed
Bus users:	Between 32 and 256 per segment (see "unit load" above)
Transmission speed:	300, 600, 1200, 2400, 4800, 9600, 19,200, 38,400, 57,600, 115,200 baud
Transmission modes:	11-bit format – 1 stop bit with even parity (8E1) 11-bit format – 1 stop bit with odd parity (8O1) 11-bit format – 2 stop bits, no parity (8N2) 10-bit format – 1 stop bit, no parity (8N1) (not a Modbus standard but often used)

Note: Transmission speed and transmission mode must be identical for all bus users!

2 Software

2.1 Coding

The Modbus standard defines the transmitted bytes as follows: they begin with the start bit which is followed by the least significant bit (LSB first) and then all bits up to the most significant bit (MSB), followed by a parity bit (even or odd) and a stop bit, or as a variant no parity bit and two stop bits instead.

Note: Contrary to the Modbus standard, no parity bit and only one stop bit are frequently used.

Important: On any given bus, all slaves and the master must be configured to the same mode.

2.2 Bus Timing

Any device connected to the Modbus must be ready to receive/transmit no later than 5 seconds after power-up.

A pause of at least 3.5 character lengths must be complied with between individual frames on the Modbus. The characters (bytes) within a frame may not be separated from each other by any more than 1.5 character lengths. If separation is greater than 1.5 character lengths, the recipient must discard the frame.

In the case of speeds of greater than 19,200 baud, the Modbus specification recommends fixed values of 750 μ s for character separation time and 1750 μ s for frame separation time (see table).

PCs which control time in a strictly software-based manner may allow larger tolerances with regard to time. This may lead to framing problems, and thus to device addressing problems as well!

	Abbreviation	Time
Ready to transmit/receive after power-up	T_{Ber}	5 sec.
Response delay time (meter transmitter)	T_{AV}	10 ... 100 ms
Waiting time after response from the meter (master)	t_{AW}	> 10 ms
Time for transmitting one character	t_z	$(1 / \text{baud rate}) * x$ (x is the number of bits: x = 10 in case of 8N1, x = 11 in case of 8O1, 8E1 or 8N2)
Character separation (up to 19,200 baud)	t_{za}	$\leq 1.5 * t_{ch}$
Frame separation (up to 19,200 baud)	t_{Fa}	$\geq 3.5 * t_{ch}$
Character separation (greater than 19,200 baud)	t_{za}	$\leq 750 \mu\text{s}$
Frame separation (greater than 19,200 baud)	t_{Fa}	$\geq 1750 \mu\text{s}$

Example for 2400 baud (mode 8E1):

Time for transmitting one character	t_z	4.6 ms
Character separation	t_{za}	$\leq 6.9 \text{ ms}$
Frame separation	t_{Fa}	$\geq 16 \text{ ms}$

Example for 68,400 baud (mode 8E1):

Time for transmitting one character	t_z	286 μs
Character separation (greater than 19,200 baud)	t_{za}	$\leq 750 \mu\text{s}$
Frame separation (greater than 19,200 baud)	t_{Fa}	$\geq 1750 \mu\text{s}$

2.3 Frame Layout

According to the specification, Modbus RTU frames always have the same layout:
(All numbers are decimal numbers unless otherwise specified.)

Device Address	Function Code	Data	CRC
8-bit (commonly 0 ... 247)	8 bit	n x 8 Bit (n= 0 ... 252)	16 bit

And thus the maximum size of a Modbus frame is 256 bytes.

2.4 Addressing

The devices (slaves) have an address which can be set within a range of 1 to 247. Address 0 is reserved for broadcasts (messages to all slaves), for example setting time or baud rate. Addresses 248 to 255 are reserved. The master doesn't have its own address.

See section 5, "Control and Display Functions", with regard to setting the above listed parameters via the control keys at the multi-tariff meter.

2.5 Function Codes

The Modbus specification defines various function codes (FC). The following four function codes are used by the U228x-, U238x meter range:

Function Code	Meaning	Use
3	Read words (read holding registers)	Read parameters
4	Read values (read input register)	Read measured values
8	Diagnosis	Connection diagnostics
16	Write words (write multiple registers)	For writing parameters

2.6 Data

The data to be transmitted are contained in this part of the frame. In requests from the master to the slave, the data are always 16-bit words and the high byte is always transmitted first.

If applicable and depending on the function code, responses from the slave contain the number of the following 16-bit data words as a byte value.

2.7 CRC Calculation (cyclic redundancy check)

Calculation is carried out over all of a frame's characters, except for those of the CRC byte. The low CRC byte (CRC LByte) is the first in the frame, followed by the high byte (CRC Hbyte). The recipient of the frame also calculates the CRC and compares it with the received CRC.

Example of CRC (16) Calculation

/*CRC table for calculation with polynom 0xA001 and start value 0xFFFF, high half word*/

```
const unsigned char CRC table hi[] = {
0x00, 0xC1, 0x81, 0x40, 0x01, 0xC0, 0x80, 0x41, 0x01, 0xC0, 0x80, 0x41, 0x00, 0xC1, 0x81,
0x40, 0x01, 0xC0, 0x80, 0x41, 0x00, 0xC1, 0x81, 0x40, 0x00, 0xC1, 0x81, 0x40, 0x01, 0xC0,
0x80, 0x41, 0x01, 0xC0, 0x80, 0x41, 0x00, 0xC1, 0x81, 0x40, 0x00, 0xC1, 0x81, 0x40, 0x01,
0xC0, 0x80, 0x41, 0x00, 0xC1, 0x81, 0x40, 0x01, 0xC0, 0x80, 0x41, 0x01, 0xC0, 0x80, 0x41,
0x00, 0xC1, 0x81, 0x40, 0x01, 0xC0, 0x80, 0x41, 0x00, 0xC1, 0x81, 0x40, 0x00, 0xC1, 0x81,
0x40, 0x01, 0xC0, 0x80, 0x41, 0x00, 0xC1, 0x81, 0x40, 0x01, 0xC0, 0x80, 0x41, 0x01, 0xC0,
0x80, 0x41, 0x00, 0xC1, 0x81, 0x40, 0x01, 0xC0, 0x80, 0x41, 0x01, 0xC0, 0x80, 0x41, 0x00,
0xC1, 0x81, 0x40, 0x01, 0xC0, 0x80, 0x41, 0x01, 0xC0, 0x80, 0x41, 0x00, 0xC1, 0x81,
0x40, 0x01, 0xC0, 0x80, 0x41, 0x00, 0xC1, 0x81, 0x40, 0x01, 0xC0, 0x80, 0x41, 0x01, 0xC0,
0x80, 0x41, 0x00, 0xC1, 0x81, 0x40, 0x00, 0xC1, 0x81, 0x40, 0x01, 0xC0, 0x80, 0x41,
0x00, 0xC1, 0x81, 0x40, 0x01, 0xC0, 0x80, 0x41, 0x01, 0xC0, 0x80, 0x41, 0x00, 0xC1, 0x81,
0x40
```

```

};
/*CRC table for calculation with polynom 0xA001 and start value 0xFFFF, low half word*/
const unsigned char CRC_table_lo[] = {
0x00, 0xC0, 0xC1, 0x01, 0xC3, 0x03, 0x02, 0xC2, 0xC6, 0x06, 0x07, 0xC7, 0x05, 0xC5, 0xC4,
0x04, 0xCC, 0x0C, 0x0D, 0xCD, 0x0F, 0xCF, 0xCE, 0x0E, 0x0A, 0xCA, 0xCB, 0x0B, 0xC9, 0x09,
0x08, 0xC8, 0xD8, 0x18, 0x19, 0xD9, 0x1B, 0xDB, 0xDA, 0x1A, 0x1E, 0xDE, 0xDF, 0x1F, 0xDD,
0x1D, 0x1C, 0xDC, 0x14, 0xD4, 0xD5, 0x15, 0xD7, 0x17, 0x16, 0xD6, 0xD2, 0x12, 0x13, 0xD3,
0x11, 0xD1, 0xD0, 0x10, 0xF0, 0x30, 0x31, 0xF1, 0x33, 0xF3, 0xF2, 0x32, 0x36, 0xF6, 0xF7,
0x37, 0xF5, 0x35, 0x34, 0xF4, 0x3C, 0xFC, 0xFD, 0x3D, 0xFF, 0x3F, 0x3E, 0xFE, 0xFA, 0x3A,
0x3B, 0xFB, 0x39, 0xF9, 0xF8, 0x38, 0x28, 0xE8, 0xE9, 0x29, 0xEB, 0x2B, 0x2A, 0xEA, 0xEE,
0x2E, 0x2F, 0xEF, 0x2D, 0xED, 0xEC, 0x2C, 0xE4, 0x24, 0x25, 0xE5, 0x27, 0xE7, 0xE6, 0x26,
0x22, 0xE2, 0xE3, 0x23, 0xE1, 0x21, 0x20, 0xE0, 0xA0, 0x60, 0x61, 0xA1, 0x63, 0xA3, 0xA2,
0x62, 0x66, 0xA6, 0xA7, 0x67, 0xA5, 0x65, 0x64, 0xA4, 0x6C, 0xAC, 0xAD, 0x6D, 0xAF, 0x6F,
0x6E, 0xAE, 0xAA, 0x6A, 0x6B, 0xAB, 0x69, 0xA9, 0xA8, 0x68, 0x78, 0xB8, 0xB9, 0x79, 0xBB,
0x7B, 0x7A, 0xBA, 0xBE, 0x7E, 0x7F, 0xBF, 0x7D, 0xBD, 0xBC, 0x7C, 0xB4, 0x74, 0x75, 0xB5,
0x77, 0xB7, 0xB6, 0x76, 0x72, 0xB2, 0xB3, 0x73, 0xB1, 0x71, 0x70, 0xB0, 0x50, 0x90, 0x91,
0x51, 0x93, 0x53, 0x52, 0x92, 0x96, 0x56, 0x57, 0x97, 0x55, 0x95, 0x94, 0x54, 0x9C, 0x5C,
0x5D, 0x9D, 0x5F, 0x9F, 0x9E, 0x5E, 0x5A, 0x9A, 0x9B, 0x5B, 0x99, 0x59, 0x58, 0x98, 0x88,
0x48, 0x49, 0x89, 0x4B, 0x8B, 0x8A, 0x4A, 0x4E, 0x8E, 0x8F, 0x4F, 0x8D, 0x4D, 0x4C, 0x8C,
0x44, 0x84, 0x85, 0x45, 0x87, 0x47, 0x46, 0x86, 0x82, 0x42, 0x43, 0x83, 0x41, 0x81, 0x80,
0x40
};

unsigned short Modbus_CRC16 (unsigned char * buffer, unsigned short length)
{
    unsigned char CRCHi = 0xFF;
    unsigned char CRCLo = 0xFF;
    int Index;
    unsigned short ret;

    while( Length-- )
    {
        Index = CRCLo ^ *Buffer++ ;
        CRCLo = CRCHi ^ CRC_Table_Hi[Index];
        CRCHi = CRC_Table_Lo[Index];
    }
    ret=((unsigned short)CRCHi << 8);
    ret|= (unsigned short)CRCLo;
    return ret;
}

```

2.8 Error Handling

If a transmission error occurs, e.g. when CRC16 calculated by the recipient no longer corresponds with the transmitted CRC16, the slave doesn't send a response to the master. This provokes a timeout. The same thing happens if a nonexistent or switched-off device is addressed.

If the recipient of a frame detects another error, a corresponding error frame is sent to the master.

Address	Function Code	Data	Checksum	
			Low byte	High byte
11h	FC + 80h	Error Code	CRC16	

The received function code is returned with set MSB (**most significant bit**). This corresponds to an addition of 80h. The error code indicates an operating or a program error. The following error codes are supported:

Error Code	Description
01	The utilized function code is not supported.
02	The utilized register address is impermissible. The register is invalid or write protected.
03	Some of the utilized data values are not within the permissible range, e.g. invalid number of registers.

Note: All registers within the address range of 3000 to 10800 can only be read and written block by block with fixed length.

This is a device-specific limitation for the assurance of the data consistency of the parameters and the data within this address range. All other registers can also be read proportionately in accordance with the Modbus specification.

2.9 Function Code Examples

Function Code 03 – Read Parameters

Request Master > slave	Address	Function Code	Data				CRC
			Start address		Number of registers		
	Addr.	03	High byte	Low byte	High byte	Low byte	CRC16

Re- sponse Slave > master	Address	Function code	Data		CRC
			Number of data bits	Information	
	Addr.	03	N (8-bit)	N/2 register	CRC16

Example: Request the selected current transformer ratio (CT) at register address 10000 of the device with address 18 (in the example: 1000:1)

```
(hex) :      >>>> 12 03 27 10 00 01 crc L crc H
          <<<< 12 03 02 03 E8 crc L crc H
```

Function Code 04 – Read Measured Values

Request Master > slave	Address	Function Code	Data				CRC
			Start address		Number of registers		
	Addr.	04	High byte	Low byte	High byte	Low byte	CRC16

Re- sponse Slave > master	Address	Function Code	Data		CRC
			Number of data bits	Information	
	Addr.	04	N (8-bit)	N/2 register	CRC16

Example: Request current THD values at register addresses 105 ... 107 of the device with address 18:

```
(hex) :      >>>> 12 04 00 69 00 03 crc L crc H
          <<<< 12 04 06 00 31 00 2E 00 32 crc L crc H
```

Function Code 08 – Diagnostics

Request Master > slave	Address	Function Code	Data				CRC
			Subfunction		Data		
	Addr.	08	0	0	High byte	Low byte	CRC16

Re- sponse Slave > master	Address	Function Code	Data				CRC
			Subfunction		Data		
	Addr.	08	0	0	High byte	Low byte	CRC16

Example: A test is executed with subfunction 00 (diagnostics) in order to determine, for example, whether or not device 17 is connected and active. The data frame is returned 1:1. (Only subfunction 0 is supported.)

```
(hex) :      >>>> 11 08 00 00 00 00 crc L crc H
          <<<< 11 08 00 00 00 00 crc L crc H
```

Function Code 16 – Write Parameters

Request Master > slave	Address	Function Code (hex)	Data						CRC
			Start address		Number of registers		Number of Bytes	Information	
	Addr.	10h	Hi	Lo	Hi	Lo	N	N bytes	CRC16

Re- sponse Slave > master	Address	Function Code (hex)	Data				CRC
			Start address		Number of registers		
	Addr.	10h	Hi	Lo	Hi	Lo	CRC16

Example: Set the voltage transformer ratio at register address 10100 of the device with address 17 to 500:1.

```
(hex) :      >>>> 11 10 27 74 00 01 02 01 F4 crc L crc H
          <<<< 11 10 27 74 00 01 crc L crc H
```

Supports broadcast (message to all): parameters can be transmitted to all connected devices simultaneously via address 0.

Note: Broadcast frames are not answered.

3 Address Space

All register addresses in this document are zero-based, and are thus transmitted directly via the interface as they're listed in the tables. No conversion is required.

3.1 Address Overview

Address	Number of Registers	Description	Access
0-14	15	Voltage	R
100-110	11	Current	R
200-216	17	Power	R
300-313	14	Total energy (all tariffs)	R
400-414	15	Energy, active tariff	R
500-510	11	Operating hrs., date and time of last reset and last cutoff date	R
600-613	14	Energy, tariff 1	R
700-713	14	Energy, tariff 2	R
800-813	14	Energy, tariff 3	R
900-913	14	Energy, tariff 4	R
1000-1013	14	Energy, tariff 5	R
1100-1113	14	Energy, tariff 6	R
1200-1213	14	Energy, tariff 7	R
1300-1313	14	Energy, tariff 8	R
1400-1411	12	Energy, tariff 1, on cutoff date	R
1500-1511	12	Energy, tariff 2, on cutoff date	R
1600-1611	12	Energy, tariff 3, on cutoff date	R
1700-1711	12	Energy, tariff 4, on cutoff date	R
1800-1811	12	Energy, tariff 5, on cutoff date	R
1900-1911	12	Energy, tariff 6, on cutoff date	R
2000-2011	12	Energy, tariff 7, on cutoff date	R
2100-2111	12	Energy, tariff 8, on cutoff date	R
2200-2211	12	Resettable energy, tariff 1	R
2300-2311	12	Resettable energy, tariff 2	R
2400-2411	12	Resettable energy, tariff 3	R
2500-2511	12	Resettable energy, tariff 4	R
2600-2611	12	Resettable energy, tariff 5	R
2700-2711	12	Resettable energy, tariff 6	R
2800-2811	12	Resettable energy, tariff 7	R
2900-2911	12	Resettable energy, tariff 8	R
3000-3035	36	Features	R
3100-3115	16	Operating logbook, last entry	R
3200-3215	16	Operating logbook, previous entry	R
3300-3315	16	Operating logbook, next entry	R
3400-3431	32	Counter reading profile, last entry	R
3500-3531	32	Counter reading profile, previous entry	R
3600-3631	32	Counter reading profile, next entry	R
3700-3701	2	Version	R
10000	1	CT	R/W
10100	1	VT	R/W
10200	1	Modbus address	R/W
10300	1	Baud rate	R/W
10400	1	Counter reading profile integrating period	R/W
10500	1	Tariff selection	R/W
10600-10603	4	Device clock time	R/W
10700-10703	4	Date and time of next reset	R/W
10800-10803	4	Date and time of next cutoff date	R/W

Access: R = read, W = write

Note: All registers within the address range of 3000 to 10800 can only be read and written block by block with fixed length.

This is a device-specific limitation for the assurance of the data consistency of the parameters and the data within this address range. All other registers can also be read proportionately in accordance with the Modbus specification.

3.2 Variable Types

Standard Variable Types		
	UINT8	8-bit integer, no leading sign
	SINT8	8-bit integer, with leading sign
	UINT16	16-bit integer, no leading sign
	SINT16	16-bit integer, with leading sign
	UINT32	32-bit integer, no leading sign
	SINT32	32-bit integer, with leading sign

3.3 Format Types

3.3.1 Format Type 1 (voltage, current, power)

This format consists of two components:

- Mantissa (SINT16)
- Exponent (SINT8), the exponent is saved to the exponent register's low byte.

Exponent register:

High byte = 0	Low byte = exponent
---------------	---------------------

*Variable value = mantissa * 10 ^ exponent*

U/M of the variables: Voltage V
 Current A
 Power W or VA or VAR depending on the type of power

Example: A voltage exponent of -1 and a voltage value of 2309 is read as:

Mantissa register:

09h	05h
-----	-----

Exponent register:

0	FFh
---	-----

$2309 * 10^{-1} = 230.9 \text{ V}$

Comment: If the mantissa has a value of 8000h, this means that the variable is undefined.

3.3.2 Format Type 2 (energy)

Calibratable energy values are saved as UINT32 values.

Mantissa:

UINT32

The primary energy value is always transmitted.

Primary energy factor:

UINT32

 Exponent:

High byte = 0	Low byte = exponent
---------------	---------------------

Includes primary energy in watt hours for all meter types (regardless of energy type):

*Primary energy [Wh/varh] = mantissa * primary energy factor*

or

*Primary energy [Wh/varh] = mantissa * (10 ^ exponent)*

Example: calculation of primary active energy (import and export) of the active tariff

Active energy import [Wh] = mantissa (address 400, UINT32) * factor (address 408, UINT32)

Active energy export [Wh] = mantissa (address 402, UINT32) * factor (address 408, UINT32)

3.3.3 Format Type 3 (frequency)

Is used for frequency and is defined as follows:

Mantissa (UINT16)

Variable value = mantissa * 0.01 [Hz]

Example: a frequency mantissa of 5002 is read as

Frequency register:

13h	8Ah
-----	-----

$5002 * 0.01 = 50.02$ Hz

3.3.4 Format Type 4 (power factor)

Is used for power factor and is defined as follows:

Mantissa (SINT16)

Variable value = mantissa / 1000

Example: a power-factor mantissa of 985 is read as

Power factor register:

03h	D9h
-----	-----

$985 / 1000 = 0.985$

3.3.5 Format Type 5 (THD)

Is used for THD and is defined as follows:

Mantissa (UINT16)

Variable value = mantissa / 1000

3.3.6 Format Type 6 (error status flags 1)

This register contains the following error bits:

MSB							LSB							
NoCal	I3Hi	I2Hi	I1Hi	U3Hi	U2Hi	U1Hi		DCerr	I3Lo	I2Lo	I1Lo	U3Lo	U2Lo	U1Lo
Error Bit	Description													
U1Lo	U1 < 75% Un													
U2Lo	U2 < 75% Un													
U3Lo	U3 < 75% Un													
I1Lo	I1 < start-up													
I2Lo	I2 < start-up													
I3Lo	I3 < start-up													
DC err	DC offset too high													
	Unused													
U1Hi	U1 > 120% Un													
U2Hi	U2 > 120% Un													
U3Hi	U3 > 120% Un													
I1Hi	Maximum value for I1 exceeded													
I2Hi	Maximum value for I2 exceeded													
I3Hi	Maximum value for I3 exceeded													
	Unused													
NoCal	Device not calibrated													

3.3.7 Format Type 7 (error status flags 2)

This register contains the following error bits:

MSB							LSB							
								NRUM	FRUM		FSYNC	FHi	FLo	FNo
Error Bit	Description													
FNo	No frequency synchronization													
FLo	Frequency < 40 Hz													
FHi	Frequency > 70 Hz													
FSYNC	Cumulative frequency error													
	Unused													
FRUM	Incorrect direction of rotation													
NRUM	No direction of rotation detected													
	Unused													
	Unused													
	Unused													
	Unused													
	Unused													
	Unused													
	Unused													
	Unused													
	Unused													
	Unused													

3.3.8 Format Type 8 (RTC structure)

Structure of the Modbus frame (date and time):

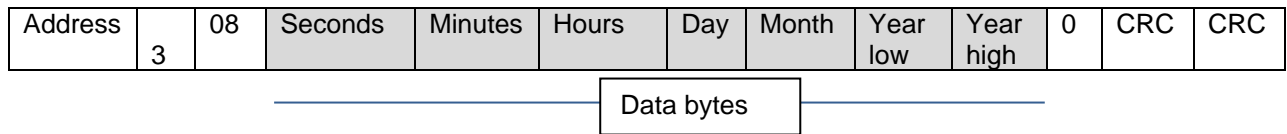

Variable	Format
Seconds	UINT8
Minutes	UINT8
Hours	UINT8
Day	UINT8
Month	UINT8
Year	UINT16

Example: Read date and time from the meter at address 1:

Master TX: 01 03 29 68 00 04 89 CD
 Slave (meter) RX: 01 03 08 **29 07 09 0E 0A DF 07** 00 2F 78

Write date and time to the meter at address 1:

TX: 01 10 29 68 00 04 08 **10 0A 09 0E 0A DF 07** 00 CA 47
 RX: 01 10 29 68 00 04 4A 48

3.3.9 Format Type 9 (interface hardware and firmware versions)

Format for hardware (HW) and firmware (FW) versions of the Modbus interface:

HW-MSB	HW-LSB	FW-MSB	FW-LSB
--------	--------	--------	--------

Variable	Format
HW-MSB	UINT8
HW-LSB	UINT8
FW-MSB	UINT8
FW-LSB	UINT8

Example: HW version = 13, FW version = 45

Variable	Value
HW-MSB	1
HW-LSB	3
FW-MSB	4
FW-LSB	5

3.3.10 Format Type 10 (operating logbook entry)

The structure consists of 32 bytes.

Logger Structure Definition

Byte Index	Variable	Format
0	Index entry	UINT16
2	Event code	UINT8
3	Parameter (1)	UINT8
4	Parameter (2)	UINT8
5	Parameter (3)	UINT8
6	Parameter (4)	UINT8
7	Parameter (5)	UINT8
8	Parameter (6)	UINT8
9	Parameter (7)	UINT8
10	Operating hours	UINT32
14	Event time stamp	Format type 8
22 ... 31	Reserve	-----

Event codes:

Event Code Beginning	Event Code End	Description	Parameter
00h		Status OK	
01h	81h	Current overload	Phase number (par 1)
02h	82h	Phase voltage too high	Phase number (par 1)
03h	83h	No frequency synchronization	
04h	84h	Frequency too low	
05h	85h	Frequency too high	
06h	86h	Incorrect phase sequence	
07h	87h	Unknown phase sequence	
08h	88h	Meter not calibrated	
09h	89h	Phase voltage too low	Phase number (par 1)
0Ah	8Ah	Analog error: DC offset too large	
0Bh	8Bh	Energy error: faulty energy status	
0Ch	8Ch	Internal communication error	
40h		Date/time changed	New time saved (format type 8 in parameters 1 ... 7)
48h		CT changed	New CT value saved (par 1)
49h		VT changed	New VT value saved (par 1)
60h		Reset occurred	
68h		The energy value has been reconstructed from cyclical backups.	

3.3.11 Format Type 11 (counter reading profile entry)

The structure consists of 64 bytes.

Byte Index	Variable	Format
0	Index entry	UINT16
2	Active tariff	UINT8
3	Exponent for energy	SINT8
4	Active energy import from all phases (mantissa)	UINT32
8	Active energy export to all phases (mantissa)	UINT32
12	Reactive energy import from all phases (mantissa)	UINT32
16	Reactive energy export to all phases (mantissa)	UINT32
20	Two additional decimal places for active energy import (mantissa 2)	UINT8
21	Two additional decimal places for active energy export (mantissa 2)	UINT8
22	Two additional decimal places for reactive energy import (mantissa 2)	UINT8
23	Two additional decimal places for reactive energy export (mantissa 2)	UINT8
24	Counter reading profile status 1	Format 11a
26	Counter reading profile status 2	Format 11b
28	Time stamp	Format 8
36	Counter reading profile interval (1, 2, 3, 4, 5, 10, 15, 30, 60 min.)	UINT8
37 ... 63	Reserve	1 byte

Note: All energy values are calculated as follows:

Display accuracy:

Energy = mantissa * 10 ^ exponent register [Wh] or [VArh]

Increased accuracy:

Energy = mantissa * 10 ^ exponent register + mantissa 2 * 10 ^ (exponent_for_energy-2) [Wh] or [VArh]

Calibratable energy is always saved to memory: the CT and VT values must be subsequently multiplied in the case of feature Q1 (adjustable CT and VT values, calibratable secondary energy).

Example:

Mantissa 1 of 4561 and mantissa 2 of 24 and exponent +3 is read as:

Mantissa 1 register:

00h	00h	11h	D5h
-----	-----	-----	-----

Mantissa 2 register:

00h	18h
-----	-----

Exponent register:

03h

$$4561 * 10 ^ (3) + 24 * 10 ^ (1) = 4,561,240 \text{ Wh}$$

3.3.12 Format Type 11a (counter reading profile status 1)

This bit field identifies which events occurred during the integrating period:

MSB

LSB

15	14	13	12	11	10	9	8	7	6	5	4	3	2	1	0
----	----	----	----	----	----	---	---	---	---	---	---	---	---	---	---

Bit	Description
0	Current 1 has exceeded the maximum value
1	Current 2 has exceeded the maximum value
2	Current 3 has exceeded the maximum value
3	Maximum value for U1 exceeded
4	Maximum value for U2 exceeded
5	Maximum value for U3 exceeded
6	No frequency synchronization possible
7	Frequency too low
8	Frequency too high
9	Incorrect phase sequence
10	Phase sequence unknown
11	Device is not calibrated
12	Analog error: DC offset too large
13	Energy error: faulty energy status
14	Internal communication error
15	The energy value has been reconstructed from cyclical backups.

Counter reading profile status 1: bits 0 ... 15 come from the operating logbook for events which have occurred during the counter reading profile interval.

3.3.13 Format Type 11a (counter reading profile status 2)

This bit field identifies which events occurred during the integrating period:

MSB

LSB

15	14	13	12	11	10	9	8	7	6	5	4	3	2	1	0
----	----	----	----	----	----	---	---	---	---	---	---	---	---	---	---

<i>Status bit</i>	<i>Description</i>
0	Shortened integrating period (not started/ended synchronous to clock time)
1	Started after a reset
2	End of the period due to tariff change
3	End of the period due to clock time change
4	-
5	-
6	-
7	-
8	-
9	-
10	-
11	-
12	-
13	-
14	-
15	-

If the counter reading profile logger entry is incomplete (after reset, tariff change or time change), this is indicated by the “incomplete counter reading profile interval” status bit.

If a reset has occurred, for example in the case of a restart after a power failure, this is indicated in the first counter reading profile entry by means of the “reset occurred” status bit (and incomplete counter reading profile logger interval). If the tariff is changed, the current counter reading profile logger value (asynchronous entry) at the point in time of the tariff change is saved with the information “tariff change”. A new counter reading profile interval is then started with the new tariff. As a result, no energy values can be lost (the entry after the tariff change and the next entry are flagged with the “incomplete counter reading profile interval” status bit).

If time is changed, the current counter reading profile logger value (asynchronous entry) is saved with the “time changed – asynchronous counter reading profile entry” status bit with the previous time stamp, after which a new counter reading profile logger period is started with the new time. As a result, no energy values can be lost (the entry after the tariff change and the next entry are flagged with the “incomplete counter reading profile interval” status bit).

3.3.14 Format Type 12 (device information)

The structure consists of 72 bytes.

Byte Index	Variable	Format
0 ... 10	Features	UINT8[11]
11 ... 18	Serial number (of the main device)	UINT8 [8]
19	Calibration date	UINT8
20	Calibration month	UINT8
21	Calibration year	UINT16
23 ... 24	Reserve	
25	Firmware version	UINT16
27 ... 31	Reserve	
32 ... 63	Product information	UINT8[32]
64 ... 70	M-Bus reserve	UINT8[7]
71	Unused	

Features:

Byte Index	Feature	Explanation
0	D	0: Gossen-Metrawatt
1	Res	Reserve
2	Res	Reserve
3	H	Auxiliary voltage, not for meters with 4 standard width units (0 = none)
4	P	Calibration 0: with MID 9: with MID + calibration certificate
5	Q	CT / VT 0: 1 1: adjustable 9: CT / VT fixed in the purchase order
6	U	Operating voltage 3: 100 V / 110 V 5: 2-wire 230 V 6: 400 V 7: 500 V
7	V	Pulse output 0: none 1: 1000 pulses/kWh, 24 V, pulse width: 30 ms, interpulse period: > 30 ms 2: S0, programmable, 24 V, pulse width: 30 ms, interpulse period: > 30 ms 3: 1000 pulses/kWh, 230V, pulse width: 30 ms, interpulse period: > 30 ms 4: S0, programmable, 230V, pulse width: 30 ms, interpulse period: > 30 ms 7: 100 pulses/kWh, 24 V, pulse width: 130 ms, interpulse period: > 130 ms 8: 1000 pulses/kWh, 24 V, pulse width: 130 ms, interpulse period: > 130 ms 9: Customer-specific order, 24 V
8	W	Bus interface 0: none 1: LON 2: MBus 4: Modbus TCP 5: BACNet 6: KNX 7: Modbus RTU
9	Z	Counter reading profile 0: no counter reading profile 1: with counter reading profile
10	S	Special variant (always 0)

Serial number:

0 th byte	1 st byte	2 nd byte	3 rd byte			4 th byte		5 th byte		6 th byte		7 th byte	
CHAR	CHAR	BCD	BCD	BCD	BCD	BCD	BCD	BCD	BCD	BCD	BCD	BCD	Reserve
"Z"	"B"	1	2	3	4	5	0	0	0	0	0	1	

The serial number consists of two letters and 10 digits (BCD format).

In the above example: ZB1234500001

Firmware version:

0 th byte		1 st byte	
0	BCD	BCD	BCD
0	2	5	6

The firmware version consists of 3 digits (BCD format).

In the above example: FW version 2.56

Product information:

Text-based information with 32 characters – defined by the manufacturer.

4 Variables in the Address Space

All register addresses in this document are zero-based, and are thus transmitted directly via the interface as they're listed in the tables. No conversion is required.

4.1 Address Space with Flexible Addressing (Modbus standard)

Register Address	Name	Length (words)	Format Type	FC	Description	OBIS
0	Voltage at the primary side between phases L1 and L2	1	1	4	Mantissa, exponent at address 12	
1	Voltage at the primary side between phases L2 and L3	1	1	4	Mantissa, exponent at address 12	
2	Voltage at the primary side between phases L3 and L1	1	1	4	Mantissa, exponent at address 12	
3	Mean value of voltage between phases at the primary side	1	1	4	Mantissa, exponent at address 12	
4	Primary phase voltage L1 to N	1	1	4	Mantissa, exponent at address 12	
5	Primary phase voltage L2 to N	1	1	4	Mantissa, exponent at address 12	
6	Primary phase voltage L3 to N	1	1	4	Mantissa, exponent at address 12	
7	Mean value of phase voltages at the primary side	1	1	4	Mantissa, exponent at address 12	
8	Primary phase voltage THD, L1 to N	1	5	4		
9	Primary phase voltage THD, L2 to N	1	5	4		
10	Primary phase voltage THD, L3 to N	1	5	4		
11	Frequency	1	3	4		
12	Voltage exponent	1	SINT8	4	Exponent in the low byte	
13	Error status flags 1	1	6	4		
14	Error status flags 2	1	7	4		
100	L1 phase current at the primary side	1	1	4	Mantissa, exponent at address 108	
101	L2 phase current at the primary side	1	1	4	Mantissa, exponent at address 108	
102	L3 phase current at the primary side	1	1	4	Mantissa, exponent at address 108	
103	Mean value of phase currents at the primary side	1	1	4	Mantissa, exponent at address 108	
104	Current in the N conductor at the primary side	1	1	4	Mantissa, exponent at address 108	
105	Phase L1 current THD	1	5	4		
106	Phase L2 current THD	1	5	4		
107	Phase L3 current THD	1	5	4		
108	Current exponent	1	SINT8	4	Exponent in the low byte	
109	Error status flags 1	1	6	4		
110	Error status flags 2	1	7	4		
200	Active power P1 at the primary side	1	1	4	Mantissa, exponent at address 212	
201	Active power P2 at the primary side	1	1	4	Mantissa, exponent at address 212	
202	Active power P3 at the primary side	1	1	4	Mantissa, exponent at address 212	
203	Active power Ptot at the primary side	1	1	4	Mantissa, exponent at address 212	
204	Reactive power Q1 at the primary side	1	1	4	Mantissa, exponent at address 212	

Register Address	Name	Length (words)	Format Type	FC	Description	OBIS
205	Reactive power Q2 at the primary side	1	1	4	Mantissa, exponent at address 212	
206	Reactive power Q3 at the primary side	1	1	4	Mantissa, exponent at address 212	
207	Reactive power Qtot at the primary side	1	1	4	Mantissa, exponent at address 212	
208	Phase 1 power factor	1	4	4		
209	Phase 2 power factor	1	4	4		
210	Phase 3 power factor	1	4	4		
211	Total power factor	1	4	4		
212	Power exponent at the primary side	1	SINT8	4	Exponent in the low byte	
213	Secondary active power, all phases	1	1	4	Mantissa, exponent at address 214	
214	Secondary power exponent	1	SINT8	4	Exponent in the low byte	
215	Error status flags 1	1	6	4		
216	Error status flags 2	1	7	4		
300	Active energy import, total (all tariffs)	2	2	4	Mantissa (see format type 2)	1.8.0
302	Active energy export, total (all tariffs)	2	2	4	Mantissa (see format type 2)	2.8.0
304	Reactive energy import, total (all tariffs)	2	2	4	Mantissa (see format type 2)	3.8.0
306	Reactive energy export, total (all tariffs)	2	2	4	Mantissa (see format type 2)	4.8.0
308	Primary energy factor	2	UINT32	4	Primary energy [Wh/varh] = mantissa * factor	
310	Energy exponent	1	SINT8	4	Secondary or primary depending on energy type	
311	Energy type	1	UINT16	4	Energy values type, 0 = secondary, 1 = primary	
312	Error status flags 1	1	6	4		
313	Error status flags 2	1	7	4		
400	Active energy import of the active tariff	2	2	4	Mantissa (see format type 2)	
402	Active energy export of the active tariff	2	2	4	Mantissa (see format type 2)	
404	Reactive energy import of the active tariff	2	2	4	Mantissa (see format type 2)	
406	Reactive energy export of the active tariff	2	2	4	Mantissa (see format type 2)	
408	Primary energy factor	2	UINT32	4	Primary energy [Wh/varh] = mantissa * factor	
410	Energy exponent	1	SINT8	4	Secondary or primary depending on energy type	
411	Energy type	1	UINT16	4	Energy values type, 0 = secondary, 1 = primary	
412	Active tariff	1	UINT16	4	Active tariff (1 ... 8)	
413	Error status flags 1	1	6	4		
414	Error status flags 2	1	7	4		
500	Operating hours	2	UINT32	4		
502	Operating hours since last reset	1	UINT16	4		
503	Point in time of last cutoff date	4	8	4		
507	Point in time of last reset	4	8	4		

Register Address	Name	Length (words)	Format Type	FC	Description	OBIS
600	Tariff 1, active energy import	2	2	4	Mantissa (see format type 2)	1.8.1
602	Tariff 1, active energy export	2	2	4	Mantissa (see format type 2)	2.8.1
604	Tariff 1, reactive energy import	2	2	4	Mantissa (see format type 2)	3.8.1
606	Tariff 1, reactive exergy export	2	2	4	Mantissa (see format type 2)	4.8.1
608	Primary energy factor	2	UINT32	4	Primary energy [Wh/varh] = mantissa * factor	
610	Energy exponent	1	SINT8	4	Exponent in the low byte	
611	Energy type	1	5	4	Energy values type, 0 = secondary, 1 = primary	
612	Error status flags 1	1	6	4		
613	Error status flags 2	1	7	4		
700	Tariff 2, active energy import	2	2	4	Mantissa (see format type 2)	1.8.2
702	Tariff 2, active energy export	2	2	4	Mantissa (see format type 2)	2.8.2
704	Tariff 2, reactive energy import	2	2	4	Mantissa (see format type 2)	3.8.2
706	Tariff 2, reactive exergy export	2	2	4	Mantissa (see format type 2)	4.8.2
708	Primary energy factor	2	UINT32	4	Primary energy [Wh/varh] = mantissa * factor	
710	Energy exponent	1	SINT8	4	Secondary or primary depending on energy type	
711	Energy type	1	5	4	Energy values type, 0 = secondary, 1 = primary	
712	Error status flags 1	1	6	4		
713	Error status flags 2	1	7	4		
800	Tariff 3, active energy import	2	2	4	Mantissa (see format type 2)	1.8.3
802	Tariff 3, active energy export	2	2	4	Mantissa (see format type 2)	2.8.3
804	Tariff 3, reactive energy import	2	2	4	Mantissa (see format type 2)	3.8.3
806	Tariff 3, reactive exergy export	2	2	4	Mantissa (see format type 2)	4.8.3
808	Primary energy factor	2	UINT32	4	Primary energy [Wh/varh] = mantissa * factor	
810	Energy exponent	1	SINT8	4	Secondary or primary depending on energy type	
811	Energy type	1	5	4	Energy values type, 0 = secondary, 1 = primary	
812	Error status flags 1	1	6	4		
813	Error status flags 2	1	7	4		
900	Tariff 4, active energy import	2	2	4	Mantissa (see format type 2)	1.8.4
902	Tariff 4, active energy export	2	2	4	Mantissa (see format type 2)	2.8.4
904	Tariff 4, reactive energy import	2	2	4	Mantissa (see format type 2)	3.8.4
906	Tariff 4, reactive exergy export	2	2	4	Mantissa (see format type 2)	4.8.4
908	Primary energy factor	2	UINT32	4	Primary energy [Wh/varh] = mantissa * factor	
910	Energy exponent	1	SINT8	4	Secondary or primary depending on energy type	
911	Energy type	1	5	4	Energy values type, 0 = secondary, 1 = primary	
912	Error status flags 1	1	6	4		
913	Error status flags 2	1	7	4		
1000	Tariff 5, active energy import	2	2	4	Mantissa (see format type 2)	1.8.5
1002	Tariff 5, active energy export	2	2	4	Mantissa (see format type 2)	2.8.5
1004	Tariff 5, reactive energy import	2	2	4	Mantissa (see format type 2)	3.8.5
1006	Tariff 5, reactive exergy export	2	2	4	Mantissa (see format type 2)	4.8.5

Register Address	Name	Length (words)	Format Type	FC	Description	OBIS
1008	Primary energy factor	2	UINT32	4	Primary energy [Wh/varh] = mantissa * factor	
1010	Energy exponent	1	SINT8	4	Secondary or primary depending on energy type	
1011	Energy type	1	5	4	Energy values type, 0 = secondary, 1 = primary	
1012	Error status flags 1	1	6	4		
1013	Error status flags 2	1	7	4		
1100	Tariff 6, active energy import	2	2	4	Mantissa (see format type 2)	1.8.6
1102	Tariff 6, active energy export	2	2	4	Mantissa (see format type 2)	2.8.6
1104	Tariff 6, reactive energy import	2	2	4	Mantissa (see format type 2)	3.8.6
1106	Tariff 6, reactive exergy export	2	2	4	Mantissa (see format type 2)	4.8.6
1108	Primary energy factor	2	UINT32	4	Primary energy [Wh/varh] = mantissa * factor	
1110	Energy exponent	1	SINT8	4	Secondary or primary depending on energy type	
1111	Energy type	1	5	4	Energy values type, 0 = secondary, 1 = primary	
1112	Error status flags 1	1	6	4		
1113	Error status flags 2	1	7	4		
1200	Tariff 7, active energy import	2	2	4	Mantissa (see format type 2)	1.8.7
1202	Tariff 7, active energy export	2	2	4	Mantissa (see format type 2)	2.8.7
1204	Tariff 7, reactive energy import	2	2	4	Mantissa (see format type 2)	3.8.7
1206	Tariff 7, reactive exergy export	2	2	4	Mantissa (see format type 2)	4.8.7
1208	Primary energy factor	2	UINT32	4	Primary energy [Wh/varh] = mantissa * factor	
1210	Energy exponent	1	SINT8	4	Secondary or primary depending on energy type	
1211	Energy type	1	5	4	Energy values type, 0 = secondary, 1 = primary	
1212	Error status flags 1	1	6	4		
1213	Error status flags 2	1	7	4		
1300	Tariff 8, active energy import	2	2	4	Mantissa (see format type 2)	1.8.8
1302	Tariff 8, active energy export	2	2	4	Mantissa (see format type 2)	2.8.8
1304	Tariff 8, reactive energy import	2	2	4	Mantissa (see format type 2)	3.8.8
1306	Tariff 8, reactive exergy export	2	2	4	Mantissa (see format type 2)	4.8.8
1308	Primary energy factor	2	UINT32	4	Primary energy [Wh/varh] = mantissa * factor	
1310	Energy exponent	1	SINT8	4	Secondary or primary depending on energy type	
1311	Energy type	1	5	4	Energy values type, 0 = secondary, 1 = primary	
1312	Error status flags 1	1	6	4		
1313	Error status flags 2	1	7	4		
1400	Active energy import, tariff 1, on cutoff date	2	2	4	Mantissa (see format type 2)	
1402	Active energy export, tariff 1, on cutoff date	2	2	4	Mantissa (see format type 2)	
1404	Reactive energy import, tariff 1, on cutoff date	2	2	4	Mantissa (see format type 2)	
1406	Reactive energy export, tariff 1, on cutoff date	2	2	4	Mantissa (see format type 2)	
1408	Primary energy factor	2	UINT32	4	Primary energy [Wh/varh] = mantissa * factor	
1410	Energy exponent	1	SINT8	4	Secondary or primary depending on energy type	

Register Address	Name	Length (words)	Format Type	FC	Description	OBIS
1411	Energy type	1	5	4	Energy values type, 0 = secondary, 1 = primary	
1500	Active energy import, tariff 2, on cutoff date	2	2	4	Mantissa (see format type 2)	
1502	Active energy export, tariff 2, on cutoff date	2	2	4	Mantissa (see format type 2)	
1504	Reactive energy import, tariff 2, on cutoff date	2	2	4	Mantissa (see format type 2)	
1506	Reactive energy export, tariff 2, on cutoff date	2	2	4	Mantissa (see format type 2)	
1508	Primary energy factor	2	UINT32	4	Primary energy [Wh/varh] = mantissa * factor	
1510	Energy exponent	1	SINT8	4	Secondary or primary depending on energy type	
1511	Energy type	1	5	4	Energy values type, 0 = secondary, 1 = primary	
1600	Active energy import, tariff 3, on cutoff date	2	2	4	Mantissa (see format type 2)	
1602	Active energy export, tariff 3, on cutoff date	2	2	4	Mantissa (see format type 2)	
1604	Reactive energy import, tariff 3, on cutoff date	2	2	4	Mantissa (see format type 2)	
1606	Reactive energy export, tariff 3, on cutoff date	2	2	4	Mantissa (see format type 2)	
1608	Primary energy factor	2	UINT32	4	Primary energy [Wh/varh] = mantissa * factor	
1610	Energy exponent	1	SINT8	4	Secondary or primary depending on energy type	
1611	Energy type	1	5	4	Energy values type, 0 = secondary, 1 = primary	
1700	Active energy import, tariff 4, on cutoff date	2	2	4	Mantissa (see format type 2)	
1702	Active energy export, tariff 4, on cutoff date	2	2	4	Mantissa (see format type 2)	
1704	Reactive energy import, tariff 4, on cutoff date	2	2	4	Mantissa (see format type 2)	
1706	Reactive energy export, tariff 4, on cutoff date	2	2	4	Mantissa (see format type 2)	
1708	Primary energy factor	2	UINT32	4	Primary energy [Wh/varh] = mantissa * factor	
1710	Energy exponent	1	SINT8	4	Secondary or primary depending on energy type	
1711	Energy type	1	5	4	Energy values type, 0 = secondary, 1 = primary	
1800	Active energy import, tariff 5, on cutoff date	2	2	4	Mantissa (see format type 2)	
1802	Active energy export, tariff 5, on cutoff date	2	2	4	Mantissa (see format type 2)	
1804	Reactive energy import, tariff 5, on cutoff date	2	2	4	Mantissa (see format type 2)	
1806	Reactive energy export, tariff 5, on cutoff date	2	2	4	Mantissa (see format type 2)	
1808	Primary energy factor	2	UINT32	4	Primary energy [Wh/varh] = mantissa * factor	
1810	Energy exponent	1	SINT8	4	Secondary or primary depending on energy type	
1811	Energy type	1	5	4	Energy values type, 0 = secondary, 1 = primary	
1900	Active energy import, tariff 6, on cutoff date	2	2	4	Mantissa (see format type 2)	
1902	Active energy export, tariff 6,	2	2	4	Mantissa (see format type 2)	

Register Address	Name	Length (words)	Format Type	FC	Description	OBIS
	on cutoff date					
1904	Reactive energy import, tariff 6, on cutoff date	2	2	4	Mantissa (see format type 2)	
1906	Reactive energy export, tariff 6, on cutoff date	2	2	4	Mantissa (see format type 2)	
1908	Primary energy factor	2	UINT32	4	Primary energy [Wh/varh] = mantissa * factor	
1910	Energy exponent	1	SINT8	4	Secondary or primary depending on energy type	
1911	Energy type	1	5	4	Energy values type, 0 = secondary, 1 = primary	
2000	Active energy import, tariff 7, on cutoff date	2	2	4	Mantissa (see format type 2)	
2002	Active energy export, tariff 7, on cutoff date	2	2	4	Mantissa (see format type 2)	
2004	Reactive energy import, tariff 7, on cutoff date	2	2	4	Mantissa (see format type 2)	
2006	Reactive energy export, tariff 7, on cutoff date	2	2	4	Mantissa (see format type 2)	
2008	Primary energy factor	2	UINT32	4	Primary energy [Wh/varh] = mantissa * factor	
2010	Energy exponent	1	SINT8	4	Secondary or primary depending on energy type	
2011	Energy type	1	5	4	Energy values type, 0 = secondary, 1 = primary	
2100	Active energy import, tariff 8, on cutoff date	2	2	4	Mantissa (see format type 2)	
2102	Active energy export, tariff 8, on cutoff date	2	2	4	Mantissa (see format type 2)	
2104	Reactive energy import, tariff 8, on cutoff date	2	2	4	Mantissa (see format type 2)	
2106	Reactive energy export, tariff 8, on cutoff date	2	2	4	Mantissa (see format type 2)	
2108	Primary energy factor	2	UINT32	4	Primary energy [Wh/varh] = mantissa * factor	
2110	Energy exponent	1	SINT8	4	Secondary or primary depending on energy type	
2111	Energy type	1	5	4	Energy values type, 0 = secondary, 1 = primary	
2200	Resettable active energy import, tariff 1	2	2	4	Mantissa (see format type 2)	
2202	Resettable active energy export, tariff 1	2	2	4	Mantissa (see format type 2)	
2204	Resettable reactive energy import, tariff 1	2	2	4	Mantissa (see format type 2)	
2206	Resettable reactive energy export, tariff 1	2	2	4	Mantissa (see format type 2)	
2208	Primary energy factor	2	UINT32	4	Primary energy [Wh/varh] = mantissa * factor	
2210	Energy exponent	1	SINT8	4	Secondary or primary depending on energy type	
2211	Energy type	1	5	4	Energy values type, 0 = secondary, 1 = primary	
2300	Resettable active energy import, tariff 2	2	2	4	Mantissa (see format type 2)	
2302	Resettable active energy export, tariff 2	2	2	4	Mantissa (see format type 2)	
2304	Resettable reactive energy import, tariff 2	2	2	4	Mantissa (see format type 2)	
2306	Resettable reactive energy export, tariff 2	2	2	4	Mantissa (see format type 2)	
2308	Primary energy factor	2	UINT32	4	Primary energy [Wh/varh] =	

Register Address	Name	Length (words)	Format Type	FC	Description	OBIS
					mantissa * factor	
2310	Energy exponent	1	SINT8	4	Secondary or primary depending on energy type	
2311	Energy type	1	5	4	Energy values type, 0 = secondary, 1 = primary	
2400	Resettable active energy import, tariff 3	2	2	4	Mantissa (see format type 2)	
2402	Resettable active energy export, tariff 3	2	2	4	Mantissa (see format type 2)	
2404	Resettable reactive energy import, tariff 3	2	2	4	Mantissa (see format type 2)	
2406	Resettable reactive energy export, tariff 3	2	2	4	Mantissa (see format type 2)	
2408	Primary energy factor	2	UINT32	4	Primary energy [Wh/varh] = mantissa * factor	
2410	Energy exponent	1	SINT8	4	Secondary or primary depending on energy type	
2411	Energy type	1	5	4	Energy values type, 0 = secondary, 1 = primary	
2500	Resettable active energy import, tariff 4	2	2	4	Mantissa (see format type 2)	
2502	Resettable active energy export, tariff 4	2	2	4	Mantissa (see format type 2)	
2504	Resettable reactive energy import, tariff 4	2	2	4	Mantissa (see format type 2)	
2506	Resettable reactive energy export, tariff 4	2	2	4	Mantissa (see format type 2)	
2508	Primary energy factor	2	UINT32	4	Primary energy [Wh/varh] = mantissa * factor	
2510	Energy exponent	1	SINT8	4	Secondary or primary depending on energy type	
2511	Energy type	1	5	4	Energy values type, 0 = secondary, 1 = primary	
2600	Resettable active energy import, tariff 5	2	2	4	Mantissa (see format type 2)	
2602	Resettable active energy export, tariff 5	2	2	4	Mantissa (see format type 2)	
2604	Resettable reactive energy import, tariff 5	2	2	4	Mantissa (see format type 2)	
2606	Resettable reactive energy export, tariff 5	2	2	4	Mantissa (see format type 2)	
2608	Primary energy factor	2	UINT32	4	Primary energy [Wh/varh] = mantissa * factor	
2610	Energy exponent	1	SINT8	4	Secondary or primary depending on energy type	
2611	Energy type	1	5	4	Energy values type, 0 = secondary, 1 = primary	
2700	Resettable active energy import, tariff 6	2	2	4	Mantissa (see format type 2)	
2702	Resettable active energy export, tariff 6	2	2	4	Mantissa (see format type 2)	
2704	Resettable reactive energy import, tariff 6	2	2	4	Mantissa (see format type 2)	
2706	Resettable reactive energy export, tariff 6	2	2	4	Mantissa (see format type 2)	
2708	Primary energy factor	2	UINT32	4	Primary energy [Wh/varh] = mantissa * factor	
2710	Energy exponent	1	SINT8	4	Secondary or primary depending on energy type	
2711	Energy type	1	5	4	Energy values type, 0 = secondary, 1 = primary	

Register Address	Name	Length (words)	Format Type	FC	Description	OBIS
2800	Resettable active energy import, tariff 7	2	2	4	Mantissa (see format type 2)	
2802	Resettable active energy export, tariff 7	2	2	4	Mantissa (see format type 2)	
2804	Resettable reactive energy import, tariff 7	2	2	4	Mantissa (see format type 2)	
2806	Resettable reactive energy export, tariff 7	2	2	4	Mantissa (see format type 2)	
2808	Primary energy factor	2	UINT32	4	Primary energy [Wh/varh] = mantissa * factor	
2810	Energy exponent	1	SINT8	4	Secondary or primary depending on energy type	
2811	Energy type	1	5	4	Energy values type, 0 = secondary, 1 = primary	
2900	Resettable active energy import, tariff 8	2	2	4	Mantissa (see format type 2)	
2902	Resettable active energy export, tariff 8	2	2	4	Mantissa (see format type 2)	
2904	Resettable reactive energy import, tariff 8	2	2	4	Mantissa (see format type 2)	
2906	Resettable reactive energy export, tariff 8	2	2	4	Mantissa (see format type 2)	
2908	Primary energy factor	2	UINT32	4	Primary energy [Wh/varh] = mantissa * factor	
2910	Energy exponent	1	SINT8	4	Secondary or primary depending on energy type	
2911	Energy type	1	5	4	Energy values type, 0 = secondary, 1 = primary	

4.2 Address Space with Fixed Block Size

Register Address	Name	Fixed Length (words)	Format Type	FC	Description
3000	Features	36	12	4	Device options and information
3100	Operating logbook, last entry	16	10	4	
3200	Operating logbook, previous entry	16	10	4	
3300	Operating logbook, next entry	16	10	4	
3400	Counter reading profile, last entry	32	11	4	
3500	Counter reading profile, previous entry	32	11	4	
3600	Counter reading profile, next entry	32	11	4	
3700	HW and FW versions	2	9	4	Interface HW and FW versions
10000	Current transformer ratio (CT)	1	UINT16	16 / 3	Limit values exist for VT x CT
10100	Voltage transformer ratio (VT)	1	UINT16	16 / 3	Limit values exist for VT x CT
10200	Device address	1	UINT16	16 / 3	The address can be changed within a range of 1 ... 247.
10300	Baud rate	1	UINT16	16 / 3	300, 600, 1200, 2400, 4800, 9600, 19,200, 38,400, 57,600, 115,200
10400	Counter reading profile integrating period	1	UINT16	16 / 3	Selectable settings: 1, 2, 3, 4, 5, 10, 15, 30, 60 (minutes)
10500	Tariff selection	1	UINT16	16 / 3	Tariff selection: 1 ... 8 or 0 0 means that hardware tariff selection is active. Observe section 6.2.
10600	Device clock time at the meter	4	8	16 / 3	
10700	Date and time for resetting	4	8	16 / 3	
10800	Date and time of the cutoff date	4	8	16 / 3	

5 Control and Display Functions

Parameter Settings Overview (excerpt from operating instructions 3-349-868-01, supplement including Modbus RTU parameter settings)

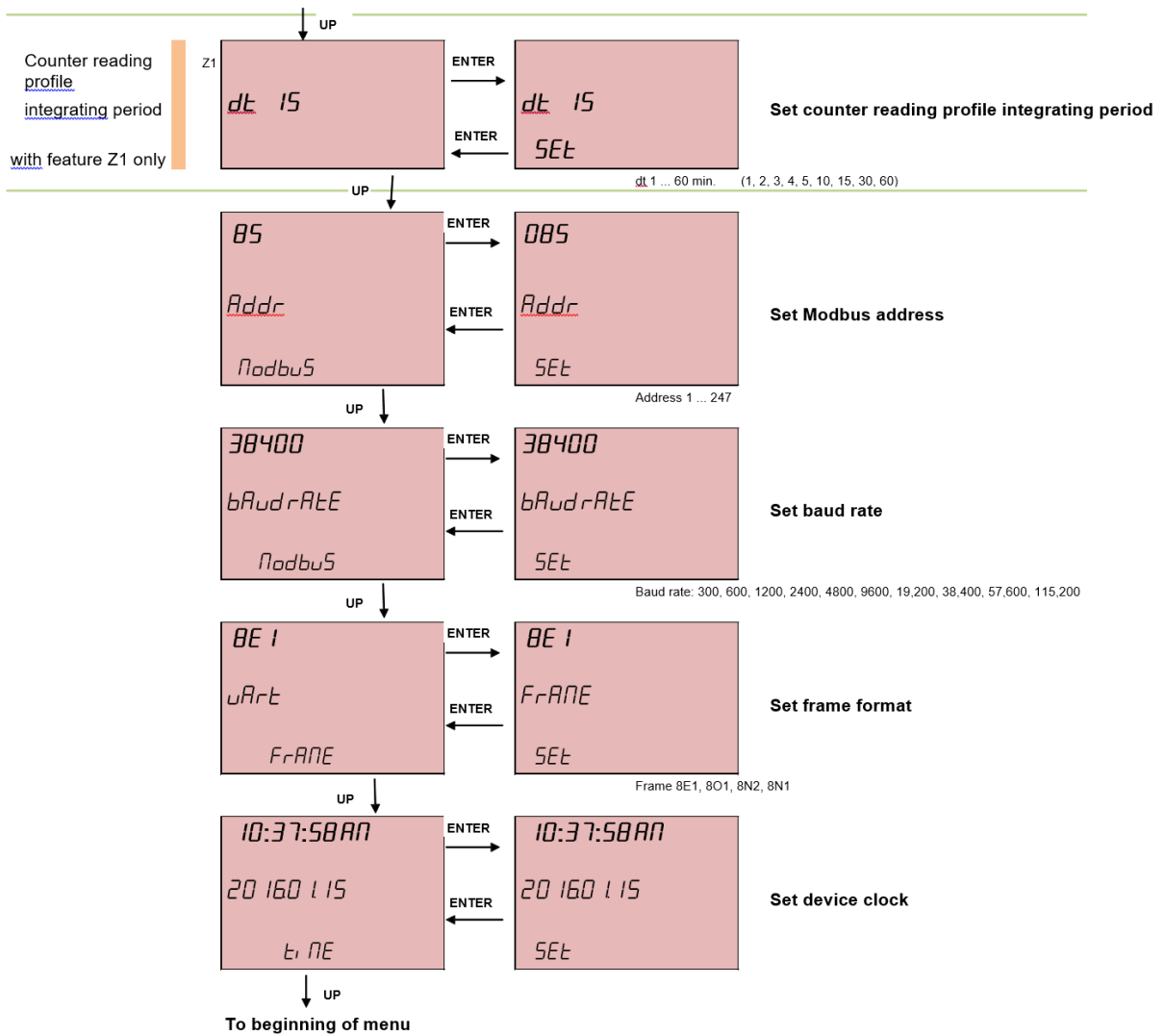

6 Application Notes

6.1 Notes regarding Initial Start-Up

- For the purpose of initial start-up, select a unique Modbus address for the meter and configure additional communication parameters if applicable.
- The frame format is preset to 8 bits, 1 stop bit and even parity (8E1) in accordance with the Modbus standard. The frame format can be changed, but this is only possible via the menu directly at the device (see section 5).
- **In the case of type U2x89 U3 meters (4-wire meters with phase voltage of 57.7 / 63.5 V), neither the interface function, counter reading profile logging (with Z1 only) nor device background illumination work during single phase operation. Other meter functions are not impaired.**
- If the tariff change will be triggered via the interface, this must take place once after pressing the enable key (see section 6.2 below).

6.2 Tariff Change via Interface

- The currently selected energy metering tariff can be viewed in register 414.
- The interface can specify a tariff by writing a value of 1 to 8 to register 10500, in which case the hardware tariff input is ignored.
- If a value of 0 (default value) is written to register 10500, the meter's tariff is specified via the tariff input.
- **However, in order to initially specify the tariff via the interface (value of 1 to 8 at address 10500) after previous hardware control (indicated by a value of 0 at register address 10500), the enable key on the device must first be pressed and the key must not appear at the device display. The setting is otherwise ignored by the device!**
- As long as a fixed tariff is selected in register 10500 (a value of 1 to 8), the tariff can always be changed via the interface.
- Entering a value of 0 to the register address makes it possible to switch back to hardware control.

6.3 Operating Logbook and Counter reading profile

The operating logbook and the counter reading profile are read out sequentially from the latest to the oldest entry. The procedure is as follows:

- By reading **exactly** 16 words (operating logbook) or 32 words (counter reading profile) from register address 3100 or 3400 respectively, the last (newest) entry is read in its entirety.
- Subsequently, the next oldest entry is always retrieved by reading **exactly** 16 or 32 words from address 3200 or 3500 respectively.
- Previously retrieved values can be read out once again by reading **exactly** 16 or 32 words from address 3300 or 3600 respectively, for example in the case of transmission problems etc.

Contents of the operating logbook:

- Events are logged with time stamp.
- Events are logged once again when they disappear and their disappearance is indicated.
- Parameters: Relevant parameters are also logged depending on the event.

Counter reading profile function:

- At the end of each integrating period, all 4 energy values for the current tariff are saved to memory with enhanced accuracy along with time stamp and status.
- The integrating period is always ended synchronous to clock time, unless an event starts a new period (e.g. tariff change, time change).
- The status represents a cumulative view of events which have occurred during the integrating period.
- Incomplete integrating periods are identified.
- In the case of a tariff change or a time change, the integrating period is interrupted, the value is stored along with the old tariff or time and a new period is started.

6.4 Cutoff Date Meter

The date and time at which the meter readings will be “frozen” can be preselected by writing an entry to register address 10800 (see table 4.2), i.e. the current energy value status is copied to a special data range and can be read out later (cutoff date energy values).

The point in time at which cutoff date energy values were recorded can be found at addresses 503 to 506, and the energy values for tariffs 1 to 8 in registers 1400 to 2111 (see table 4.1).

The following rules apply to the specification of a cutoff date:

- Point in time in the future: cutoff date energy values are updated at this point in time.
- Point in time in the past: no updating of cutoff date energy values.
- Current date, time of day in the past: current device time and cutoff date energy values are saved to memory.
- An entry of 0 to day, month or year functions as a placeholder: the cutoff date energy values are updated on each corresponding date.
- Everything in date and time set to 0 (placeholder): cutoff date via device clock, every day at midnight, initial recording immediately.

6.5 Resettable Meter

Similar to the cutoff date meter, meter readings are saved and the respective differential value (= current value - value at the time of resetting) is determined.

The date and time at which the meter readings will be reset can be preselected by writing a value to register address 10700 (see table 4.2).

The point in time at which resetting has occurred can be found at addresses 507 to 510, and the energy values for tariffs 1 to 8 in registers 2200 to 2911 (see table 4.1).

The following rules apply to the specification of a reset time point:

- Point in time in the future: reset at this point in time.
- Point in time in the past: no resetting of energy values.
- Current date, time of day in the past: immediate reset with current device clock time.
- An entry of 0 to day, month or year functions as a placeholder: the energy values are reset on each corresponding date.
- Everything in date and time set to 0 (placeholder): reset via device clock, every day at midnight, initial reset immediately.

7 Product Support

If required please contact:

GMC-I Messtechnik GmbH

Industrial Product Support Hotline

Phone: +49 911 8602-500

Fax: +49 911 8602-340

e-mail: support.industrie@gossenmetrawatt.com

Prepared in Germany • Subject to change without notice • PDF version available on the Internet